

INSTALLATION INSTRUCTIONS

2013-2018 G3 Double Canopy

Elite 326 SS / Elite 326 DLX SS

PARTS LIST

1 Bow canopy frame
1 Bow canopy and boot
1 Aft canopy with zippers
1 Bow frame hardware kit
1 Rear lounge canopy and boot
1 Rear lounge frame
1 Rear lounge hardware kit

TOOLS REQUIRED

Measuring Tape
Center Punch
Drill
5/16" Drill Bit
Pencil
Allen wrench set

**WARNING**

INDICATES POTENTIAL HAZARD
THAT COULD RESULT IN DEATH
OR INJURY

**CAUTION**

INDICATES POTENTIAL
HAZARD THAT COULD
RESULT IN BOAT DAMAGE

**NOTE**

INDICATES SPECIAL INFORMATION
TO MAKE MAINTENANCE EASIER
OR INSTRUCTIONS CLEARER



NOTE:

This enclosure is designed to fit the 2013-2017 G3 Elite 326 SS/DLX SS Pontoon Boat that has the aft canopy brackets in the following locations:
 1st Aft Button 127-1/2" 2nd Aft Bracket 113" 3rd Aft Button 24"

Measurements should be taken from the end of the back deck for aft canopy brackets and as shown below aft canopy buttons, for bow, canopy buttons and hinges in the following locations

1st Bow Bracket 90" 2nd Bow Button 239"

If the brackets are off more than 1-inch in either direction, the enclosure WILL NOT FIT.

All measurements are taken to the center of the brackets.

FIG. 1

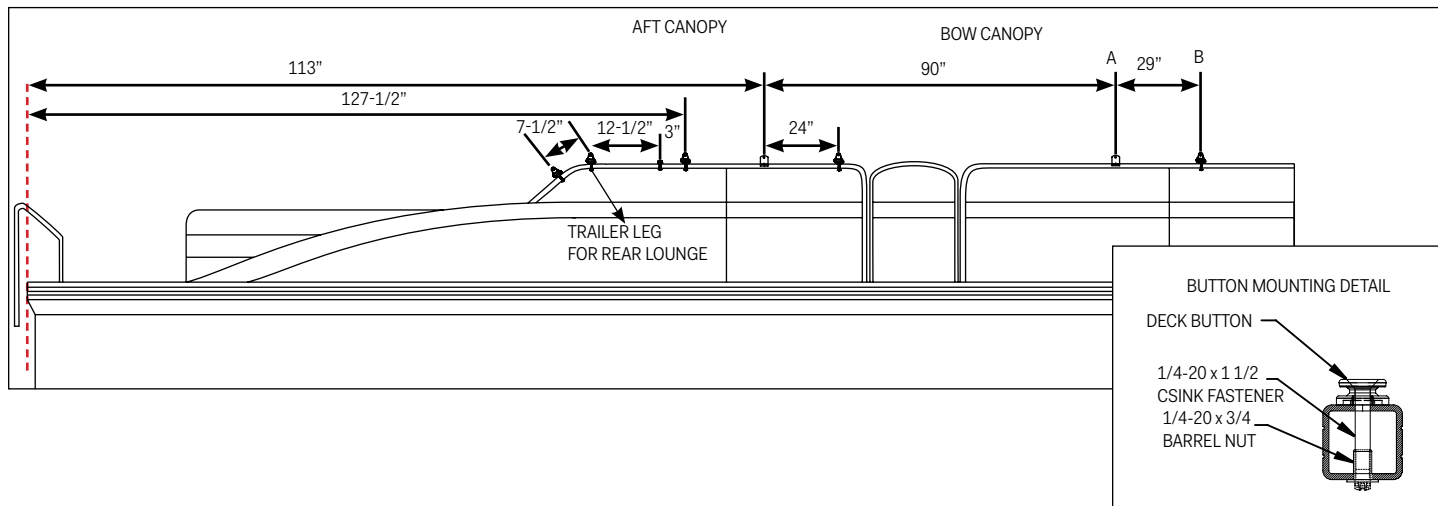

NOTE:

Your pontoon has been pre-assembled with an aft canopy and aft canopy frame from G3. The aft canopy that is supplied with the pontoon is not designed to be used with an enclosure. You must remove the standard aft canopy and replace it with the aft canopy that is supplied with the purchase of your enclosure. Once the new canopy is installed, raise the entire unit to the "up" position. Make sure the aft canopy is centered on the frame between the port and starboard sides. This step is very critical, it will determine the final appearance of your completed enclosure.

BRACKET LOCATIONS & ASSEMBLY (FIGURES 1 & 2)

STEP 1

Bracket location (A). Measure and place a mark on the top rail 90" forward from aft main bracket. Button location (B). Measure and place a mark on the top rail 29" forward from (A).

STEP 2

Center the brackets at each mark as shown in Figure 2. Transfer the centers of each hole at the bottom of the bracket on to the rail using a center punch.

STEP 3

Using 5/16" drill bit, drill holes completely through the top rail.

STEP 4

Replace the brackets. Insert a shoulder bolt from the top through the bracket and the rail. Place a barrel nut on and tighten (Figure 2).

STEP 5

Follow the same procedure for the other side.

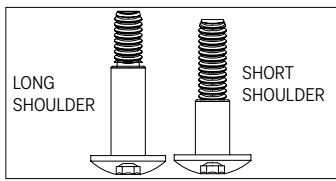
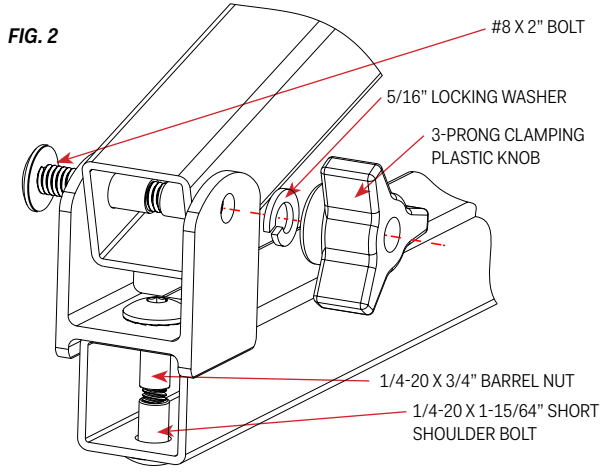

! **CAUTION**
 TO PREVENT DAMAGE TO THE TOP RAIL, IT IS RECOMMENDED TO DRILL A PILOT HOLE FIRST.

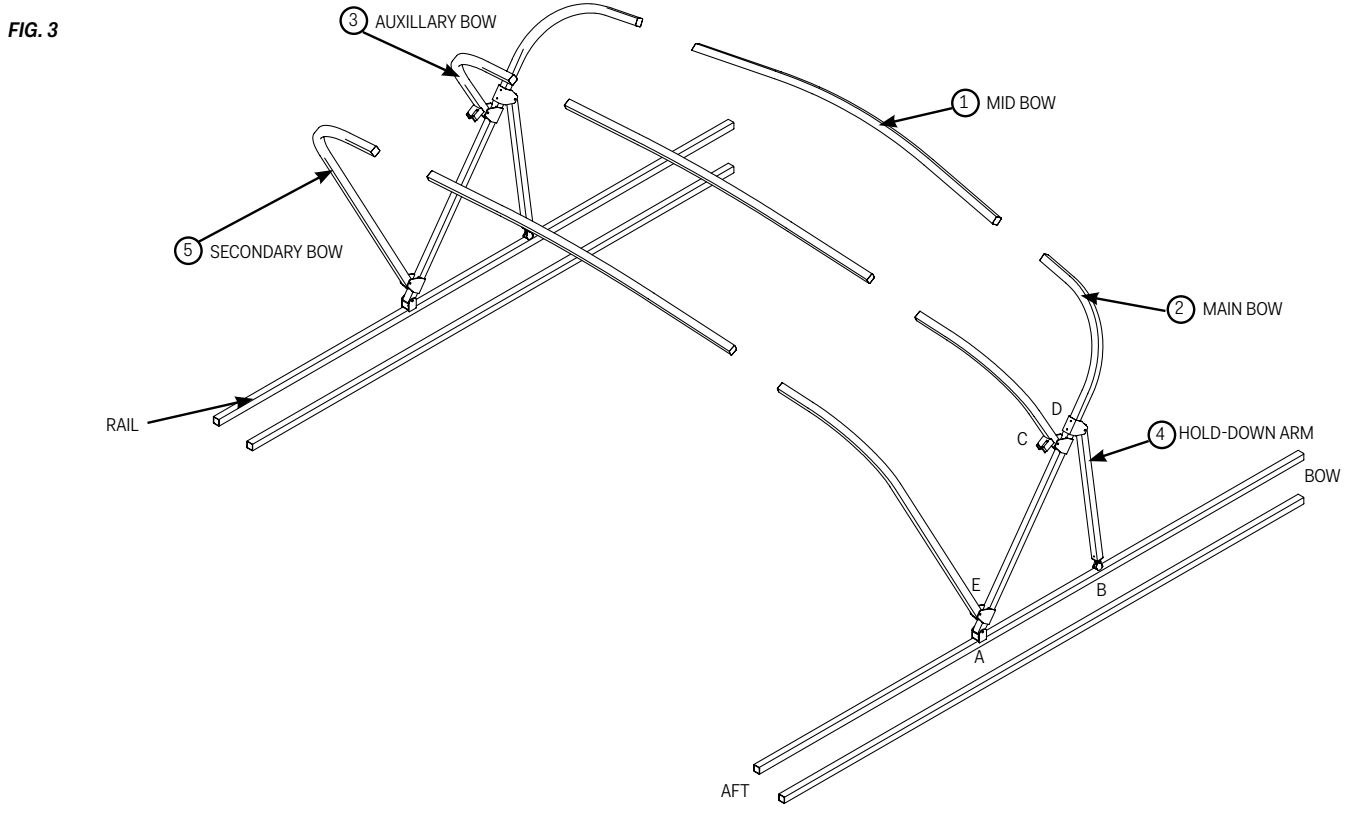

BOW CANOPY & BOW CANOPY FRAME ASSEMBLY (FIGURE 3)

STEP 1

Insert mid bow (1) into the main bow (2) making sure that the bend in the center of the mid bow is to the top following the curve of the frame.

STEP 2

Assemble secondary bow (5) and auxillary bow (3) in the same manner.

STEP 3

Attach auxillary bow (3) to the bracket on main frame (C) and secondary bow (5) to bracket (E) with 1/4-20 x 1-5/16" long shoulder bolt and barrel nut.

STEP 4

Place the ends of main bow (2) into bracket (A) make sure that bracket (D) for hold-down-arm (4) is facing down. Bracket (D) measures 35" up from the bottom of the frame to the center of the bracket. Insert #8 x 2" bolt with locking washer and secure with knob.

STEP 5

Zip the bow canopy to the aft canopy.

STEP 6

Zip the front pocket of the bow canopy to the main bow (2).

STEP 7

Zip center pocket to the auxillary bow (3).

STEP 8

Place end of hold down arm (4) into bracket (D) of main bow (2), insert 1/4-20 x 2" long shoulder bolt and acorn nut.

STEP 9

Center the bow canopy at this time before securing the hold down arm (4) to the pontoon. Attach hold down arm (4) to button (B) on rail.

CARE



WARNING

DO NOT TRAILER WITH ANY CANOPY TOP UP (IN RADAR ARCH POSITION) OR WITH THE ENCLOSURE ASSEMBLED!